

DQDB



INTRODUCTION

- Distributed Queue Dual Bus (DQDB IEEE 802.6) is defined for use on MANs and affects the media-access-control (MAC) sub layer.
- DQDB uses a dual bus operating in opposite directions so that a node may transmit and receive concurrently at speeds between 50 Mbps up to 600 Mbps.



Technical Data

- Distance \geq 200 km
- Medium : optical fiber
- Access Method : Timed Token Passing
- Transmission Rate : 34 - 600 Mbit/s
- Maximum no. of stations : 512

DQDB in OSI

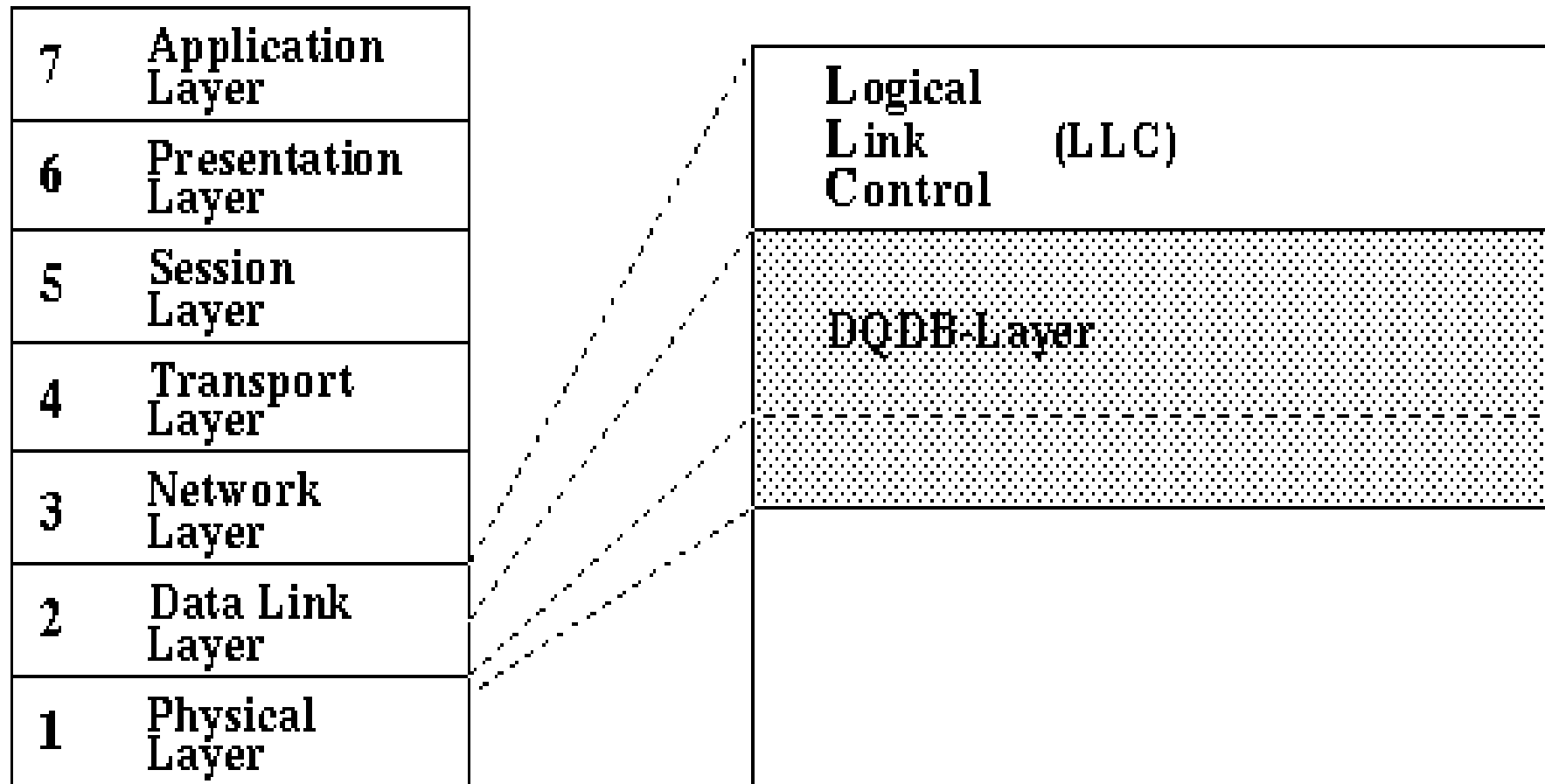

DQDB Buses and Nodes

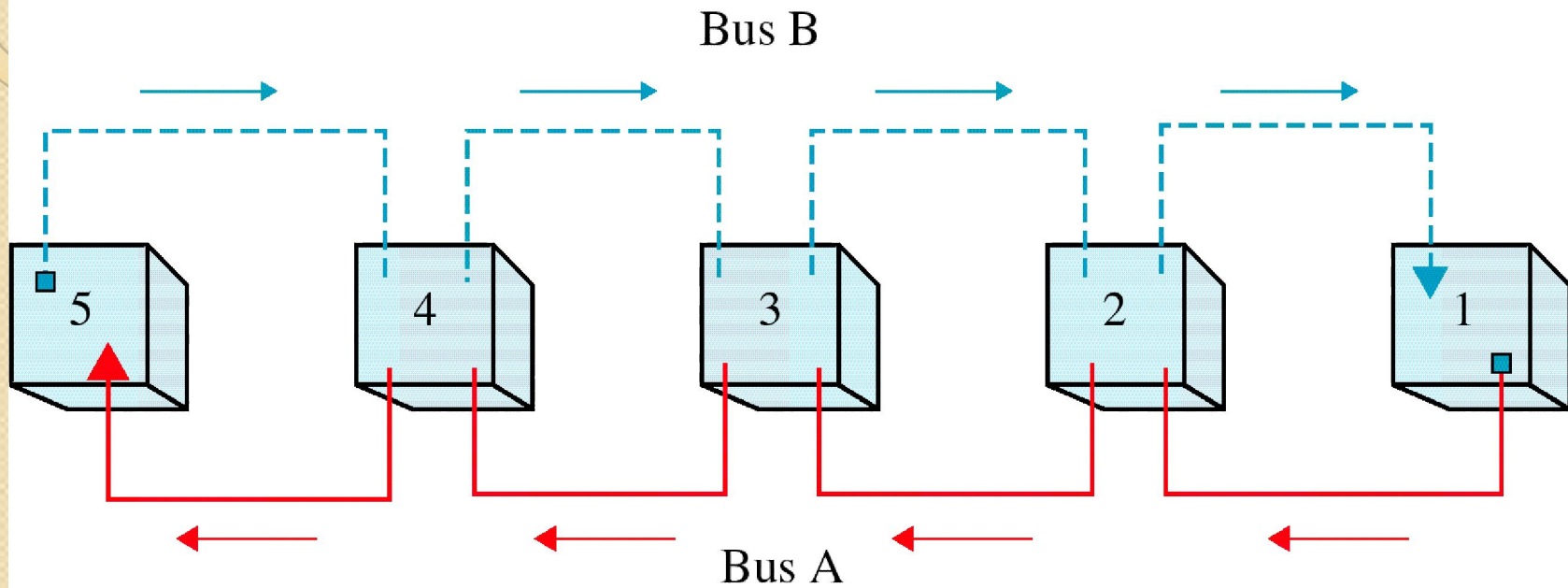



Working of DQDB

- The Head of Bus (HOB)s act a slot generators so that the bus is never quiet.
- Nodes are located logically adjacent to the bus and are promiscuous readers. They read all slots that come off the bus but may not necessarily alter any of the data.
- Nodes may be passive readers or, in an active system, they may act as repeaters so as to forestall attenuation.



Working of DQDB

- If Node 2 wishes to send data in the direction of Node 5 then it will use Bus A. This implies that it must first reserve a slot by placing a request on Bus B.
- If Node 2 wishes to send data in the direction of Node 1 it must first reserve a slot using Bus A and then send the data on Bus B.

DQDB Data Transmission

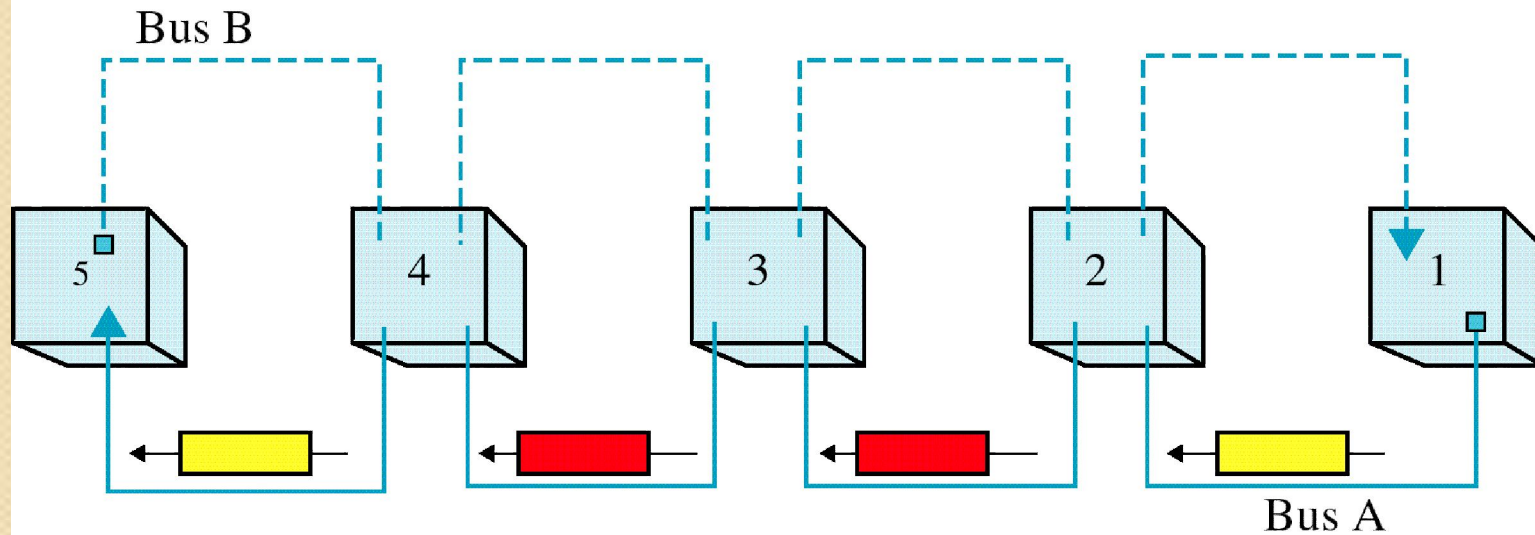

a. Station 2 sends data to station 4.

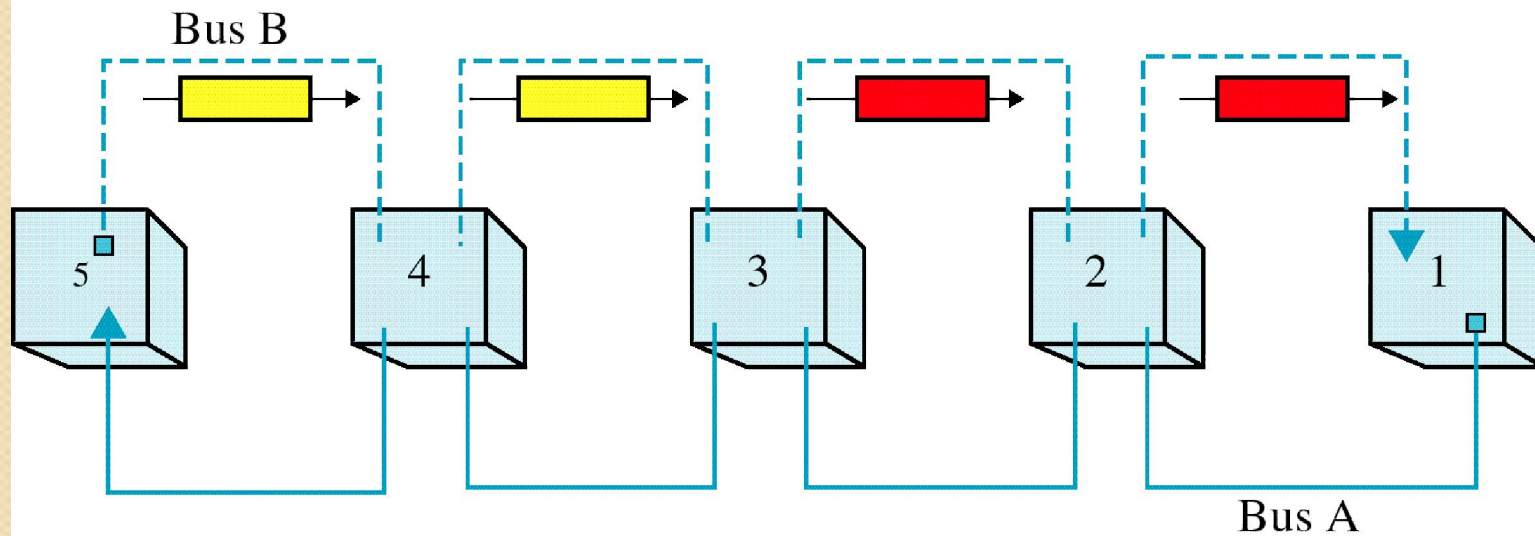

b. Station 3 sends data to station 1.

Queues



a. A queue with 5 elements.

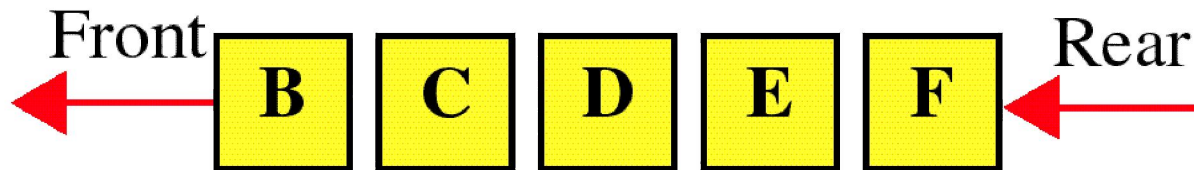

b. After removing first element

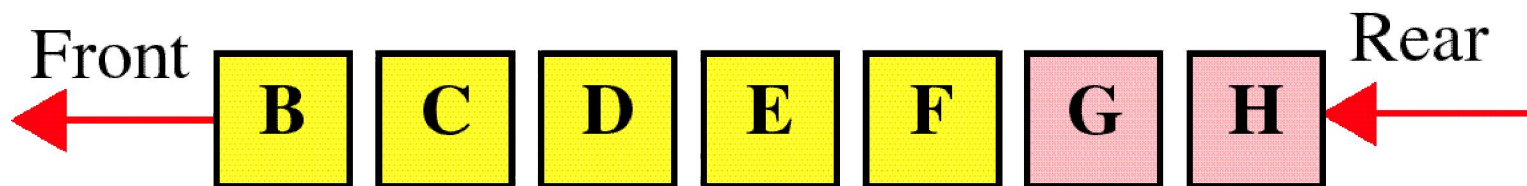

c. After inserting two elements

Distributed Queues

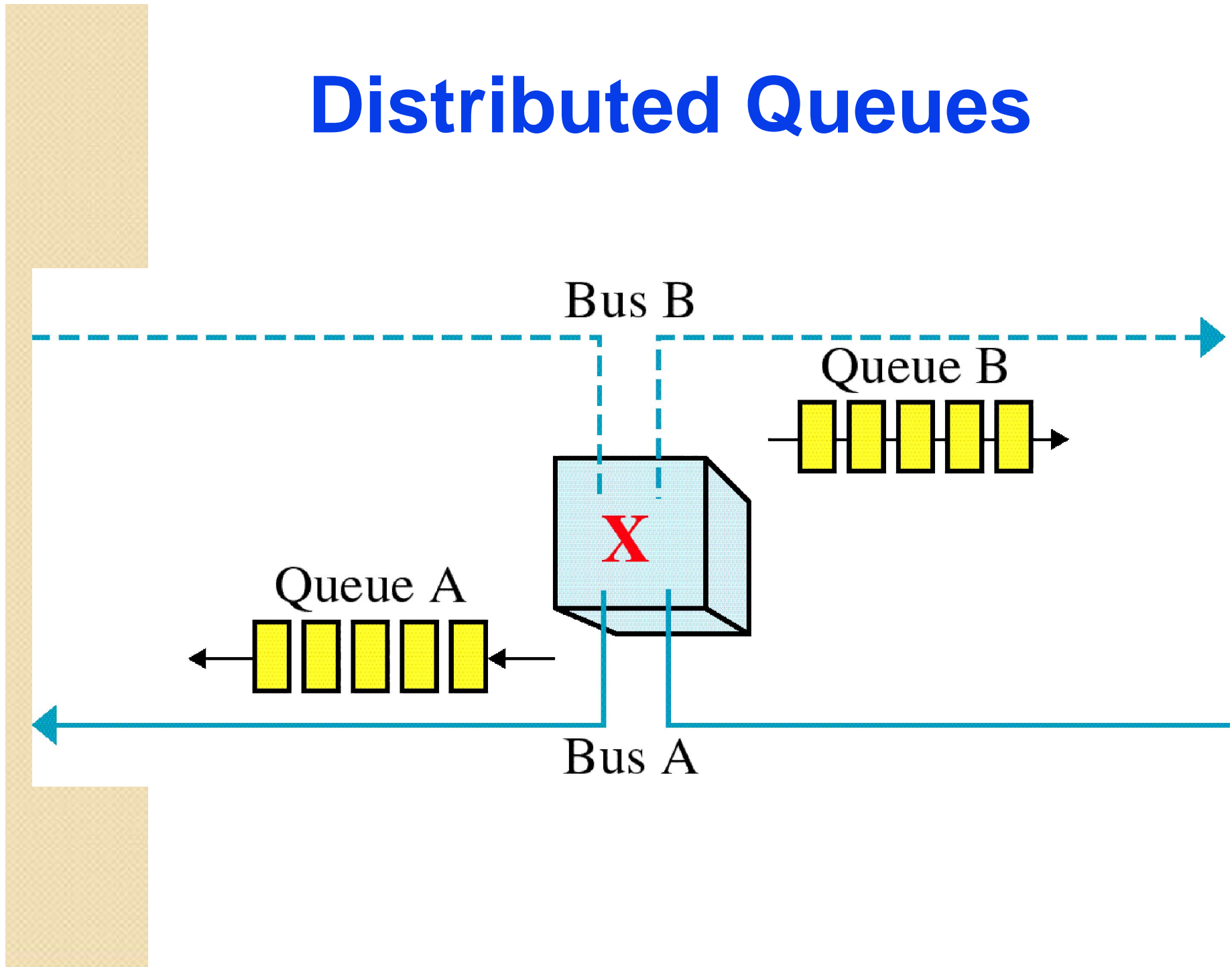

Reservation Token

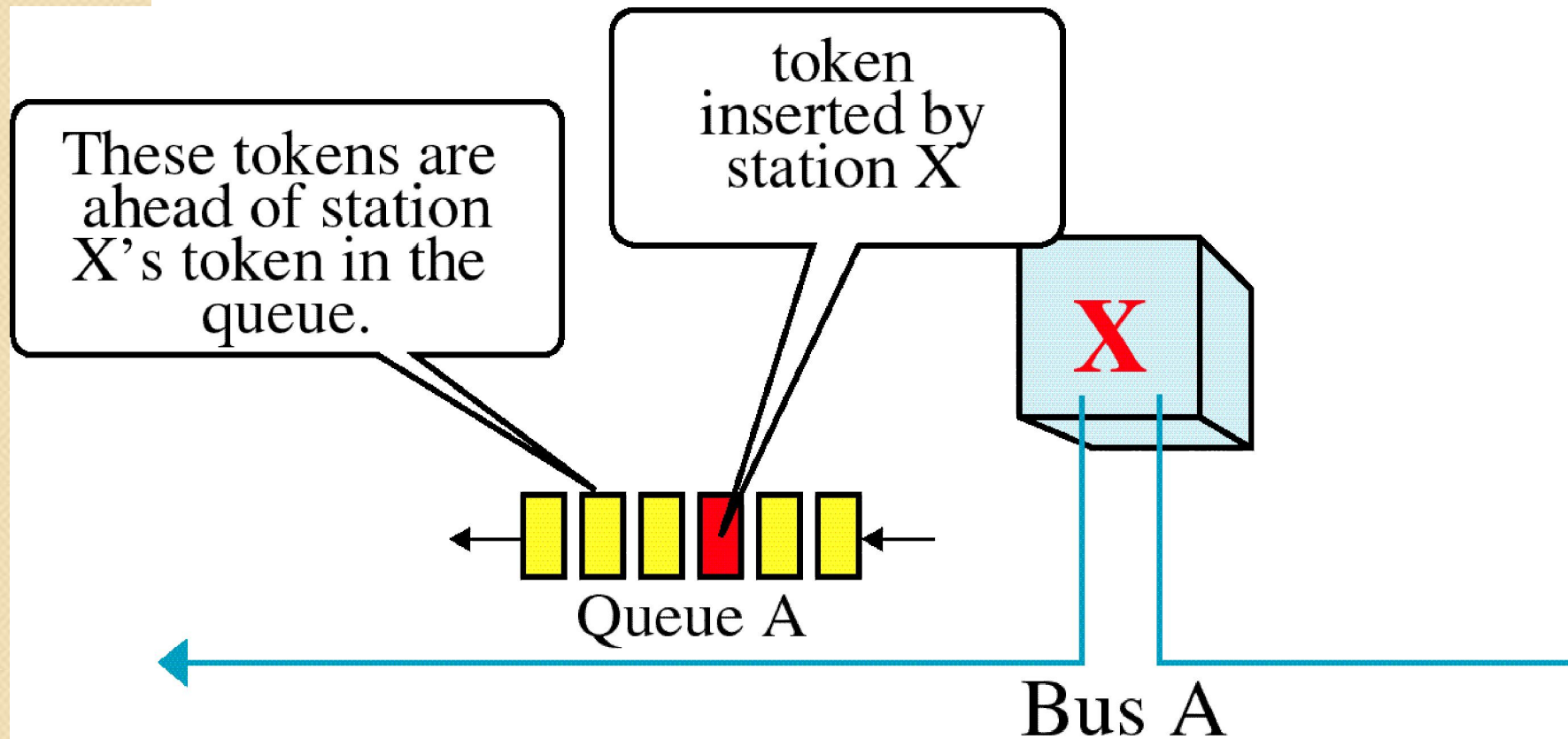



DQDB Operation

- The DQDB configuration is independent of the number of nodes and of the distances involved making DQDB ideal for high-speed transmissions
- DQDB uses 53-byte packets (52 data bytes and one access control byte) for transmissions called slots.
- Slots from different nodes are intermingled in the network traffic.

DQDB Rings

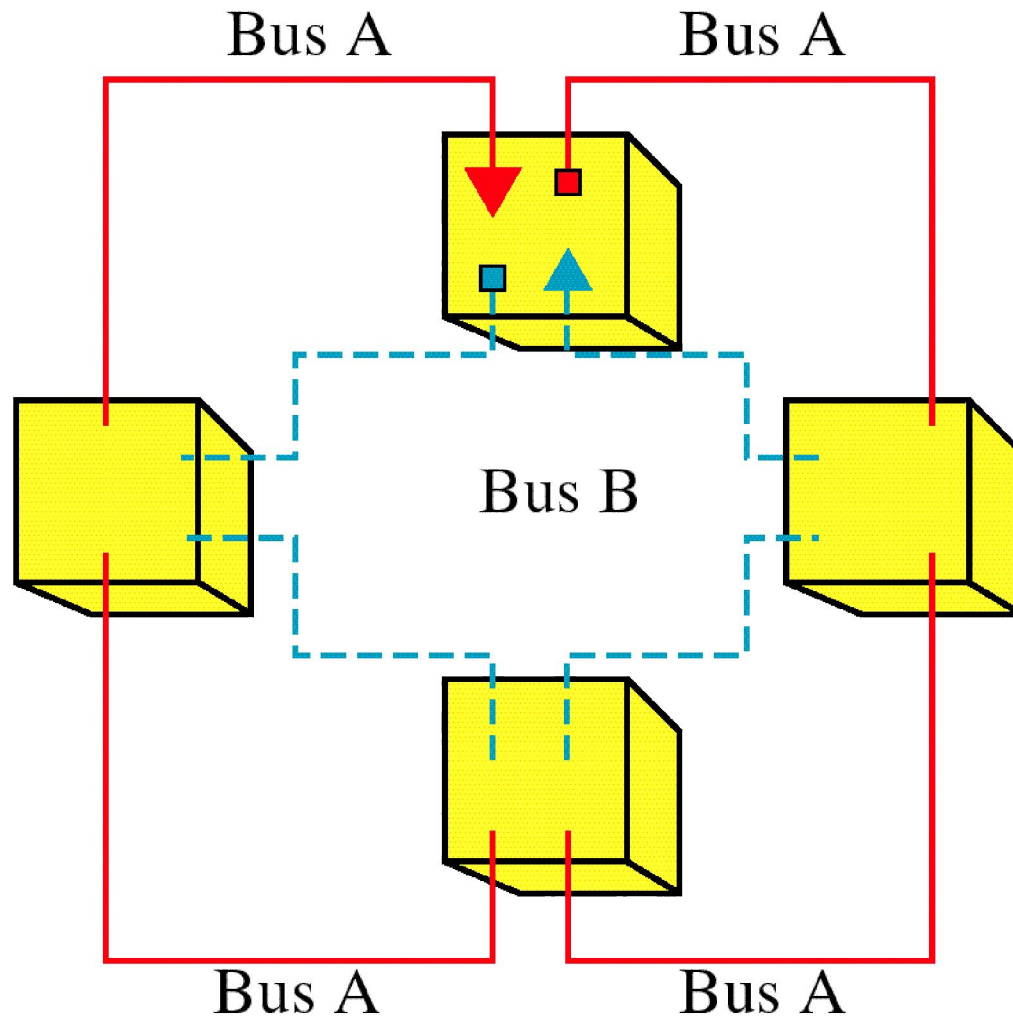

a. Ring without failure.

DQDB Rings

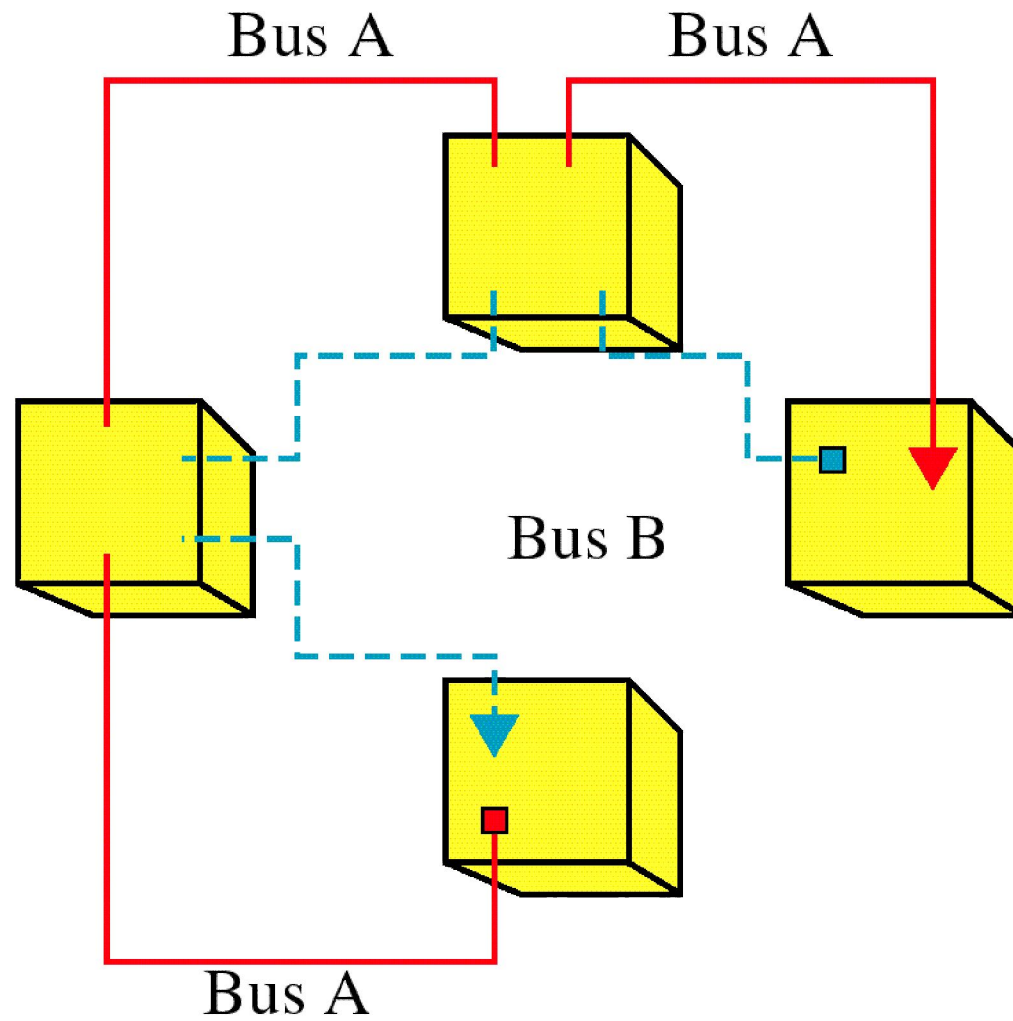

b. Ring with failure.



Applications

- DQDB provides both isochronous and asynchronous service to its users.
- Isochronous services require fixed bandwidth and bounded delay e.g. Digital voice and video.
- Asynchronous services require data services e.g. file transfer, email etc.



Scope of Research

- Priority based algorithm for slot allocation



Assignment

- What are distributed queues in DQDB?